

## Internal lining

# Installation guide

Versilux® lining



**James Hardie**  
A smarter way to build

AUSTRALIA SEPTEMBER 2014



JHA-2014  
GECA 04-2011 v2  
Panel Boards

# 1 INTRODUCTION

James Hardie Versilux® lining is a premium sanded sheet which is an ideal lining for internal high traffic areas, fire and/or acoustic walls. Versilux lining is also used for ceilings and eaves/soffit applications.

The features of Versilux lining are:

- Durable internal lining sheet.
- Suitable surface for paint finishes.
- Square edges for easy joining.
- Reliable impact resistant lining.
- Suitable for use in fire and acoustically rated systems.
- Pink sheet to identify quality James Hardie fibre cement.

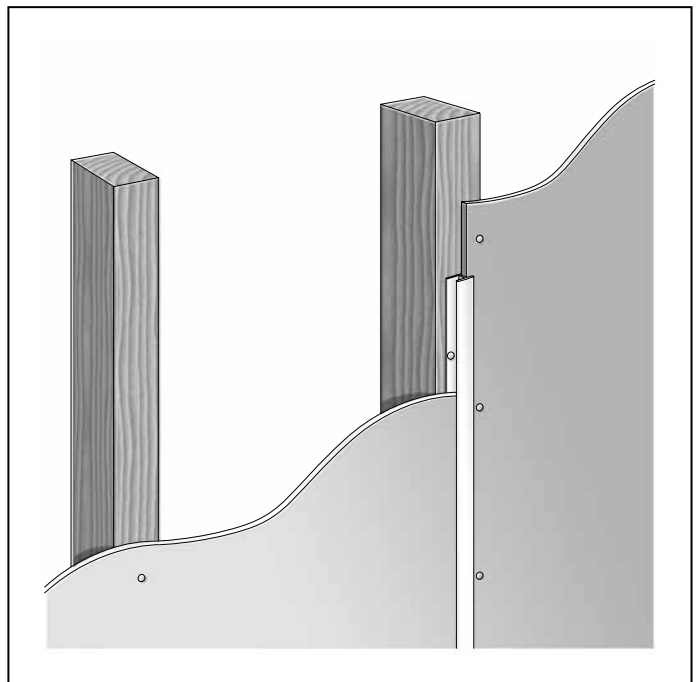

The specifier or other responsible party for the project must ensure the information and details in this guide are appropriate for the intended application and specific design and detailing is undertaken for areas which fall outside the scope of this documentation.

## Make sure your information is up to date

When specifying or installing James Hardie products, ensure you have the current manual. If you're not sure you do, or if you need more information, visit [www.jameshardie.com.au](http://www.jameshardie.com.au) or Ask James Hardie™ on 13 11 03.

## CONTENTS

<b>1</b>	<b>INTRODUCTION</b>	<b>2</b>
	Versilux® lining sheet sizes	3
	Accessories/tools supplied by James Hardie	3
	Accessories/tools not supplied by James Hardie	3
<b>2</b>	<b>SAFE WORKING PRACTICES</b>	<b>4</b>
	Warning	4
	Recommended safe working practices	4
	Working instructions	4
	Hole-forming	5
	Storage and handling	5
	Quality	5
<b>3</b>	<b>FRAMING</b>	<b>6</b>
	General	6
	Timber	6
	Steel	6
	Preparation	6
	Curved walls	6
<b>4</b>	<b>INSTALLATION</b>	<b>7</b>
	Sheet layout	7
	Fasteners	7
	Fixing to walls	7
	Fixing to ceilings	8
<b>5</b>	<b>JOINTING AND CORNERS</b>	<b>9</b>
	Jointing	9
	Corners	10
<b>6</b>	<b>PRODUCT INFORMATION</b>	<b>11</b>
	General	11
	Product mass	11
	Durability	11
	Finishes	11
	Maintenance	11
<b>7</b>	<b>WARRANTY</b>	<b>12</b>

## WE VALUE YOUR FEEDBACK

To continue with the development of our products and systems, we value your input. Please send any suggestions, including your name, contact details, and relevant sketches to:

Ask James Hardie™

Fax 02 9638 9535

[literaturefeedback@jameshardie.com.au](mailto:literaturefeedback@jameshardie.com.au)

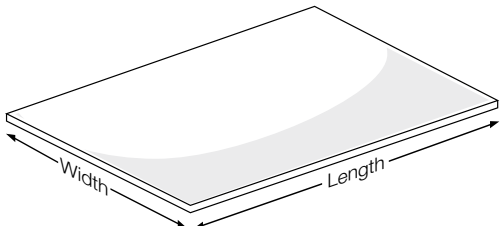

TABLE 1

VERSILUX LINING SHEET SIZES			
PRODUCT	LENGTH	WIDTH	
		900	1200
	<b>4.5 mm thickness (only available in QLD and NT)</b>		
	2400	✓	✓
	3000		✓
	3600		✓
	<b>6mm thickness</b>		
	2400		✓
	2700		✓
	3000	✓	✓
	3600		✓
	<b>9mm thickness</b>		
	2700		✓

Approx. mass: 4.5, 6 and 9mm Versilux is 6.2, 8.3 and 12.4 kg/m<sup>2</sup> respectively.

\*All dimensions and masses are approximate and subject to manufacture tolerances.

TABLE 2





ACCESSORIES / TOOLS SUPPLIED BY JAMES HARDIE			
PRODUCT	DESCRIPTION	PRODUCT	DESCRIPTION
	<b>HardieBlade™ Saw Blade. 185mm diameter</b> A 185mm diameter poly-diamond blade for fast and clean cutting of James Hardie fibre cement. Bore diameter is 20mm. 1 each. Part No. 300660		<b>James Hardie™ PVC Straight Jointer for 6mm thick sheets. 3,000mm long</b> A 3,000mm long PVC extrusion used to join 6mm thick sheets. 25 per pack. Part No. 305546
	<b>James Hardie™ Score and Snap Knife</b> A tungsten tipped knife for scoring fibre cement sheets. 20 per box. Part No. 305576		<b>James Hardie™ PVC Internal Corner Angle for 6mm thick sheets. 3,000mm long</b> A PVC extrusion, to be used with 6mm thick sheets at internal corner junctions to conceal the sheet edge. 25 per pack. Part No. 305545
	<b>HardieDrive™ Screw 32mm long</b> A class 3 finish self-tapping wing-tipped screw for fastening 6mm and 9mm Versilux sheets to 0.8mm to 1.6mm BMT steel frames. 500 per box. Part No. 305532		<b>James Hardie™ PVC External Corner Angle for 6mm thick sheets. 3,000mm long</b> A PVC extrusion, to be used with 6mm thick sheets at external corner junctions to conceal the sheet edge. 25 per pack. Part No. 305544
	<b>James Hardie™ Fibreshears</b> Electric tool for cutting fibre cement sheets. 1 each. Part No. 300653		<b>James Hardie™ PVC Cap Mould for 4.5mm thick sheets. 3,000mm long</b> A PVC extrusion used to finish 4.5mm thick sheet edges. 25 per pack. Part No. 305542
	<b>James Hardie™ PVC Straight Jointer for 4.5mm thick sheets. 2,400mm long</b> A 2,400mm long PVC extrusion used to join 4.5mm thick sheets. 25 per pack. Part No. 305538		<b>James Hardie™ PVC Cap Mould for 6mm thick sheets. 3,000mm long</b> A PVC extrusion used to finish 6mm thick sheet edges. 25 per pack. Part No. 305543
	<b>James Hardie™ PVC Straight Jointer for 4.5mm thick sheets. 3,000mm long</b> A 3,000mm long PVC extrusion used to join 4.5mm thick sheets. 25 per pack. Part No. 305541		

TABLE 3

ACCESSORIES / TOOLS NOT SUPPLIED BY JAMES HARDIE			
James Hardie recommends the following products for use in conjunction with its Versilux lining. James Hardie does not supply these products and does not provide a warranty for their use. Please contact the component manufacturer for information on their warranties and further information on their products.			
PRODUCT	DESCRIPTION	PRODUCT	DESCRIPTION
	<b>Galvanised fibre cement nails</b> 30mm x 2.8 galvanised fibre cement nails.		<b>Buildex FibreTEKS®</b> For fastening 6mm Versilux lining to 0.55mm to 0.75mm BMT steel frames. Length: 20mm ® denotes a registered mark of Buildex
	<b>Buildex FibreTEKS®</b> For fastening 9mm Versilux lining to 0.55mm to 0.75mm BMT steel frames. Length: 30mm		<b>Buildex FibreTEKS® bugle head</b> For fastening 4.5mm Versilux lining to 0.55mm to 0.75mm BMT steel frames. Length: 20mm
	<b>Hand guillotine</b> Guillotine for cutting fibre cement.		

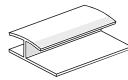
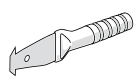
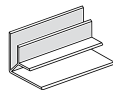
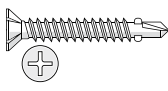
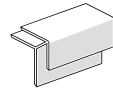
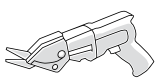
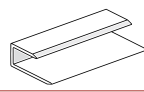
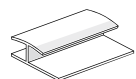
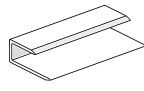
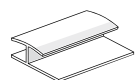
# 2 SAFE WORKING PRACTICES

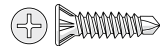
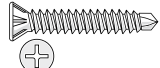
## WARNING - DO NOT BREATHE DUST AND CUT ONLY IN WELL VENTILATED AREA

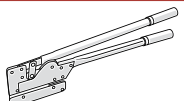
James Hardie products contain sand, a source of respirable crystalline silica which is considered by some international authorities to be a cause of cancer from some occupational sources. Breathing excessive amounts of respirable silica dust can also cause a disabling and potentially fatal lung disease called silicosis, and has been linked with other diseases. Some studies suggest smoking may increase these risks. During installation or handling: (1) work in outdoor areas with ample ventilation; (2) minimise dust when cutting by using either 'score and snap' knife, fibre cement shears or, where not feasible, use a HardieBlade™ Saw Blade and dust-reducing circular saw attached to a HEPA vacuum; (3) warn others in the immediate area to avoid breathing dust; (4) wear a properly-fitted, approved dust mask or respirator (e.g. P1 or P2) in accordance with applicable government regulations and manufacturer instructions to further limit respirable silica exposures. During clean-up, use HEPA vacuums or wet cleanup methods - never dry sweep. For further information, refer to our installation instructions and Material Safety Data Sheets available at [www.jameshardie.com.au](http://www.jameshardie.com.au). FAILURE TO ADHERE TO OUR WARNINGS, MATERIAL SAFETY DATA SHEETS, AND INSTALLATION INSTRUCTIONS MAY LEAD TO SERIOUS PERSONAL INJURY OR DEATH.

## WORKING INSTRUCTIONS

Refer to recommended safe working practices before starting any cutting or machining of product.

### Score and snap

Score and snap is a fast and efficient method of cutting James Hardie building products using James Hardie's special tungsten tipped score and snap knife.

Preferably score on the face side of the product. Score against a straight edge and repeat the action to obtain adequate depth for clean break – normally one third of sheet thickness. Snap upwards to achieve break. Smooth any rough edges with a rasp.

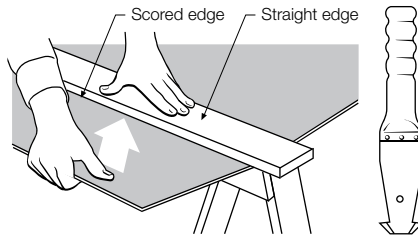

## JAMES HARDIE RECOMMENDED SAFE WORKING PRACTICES

### CUTTING OUTDOORS

1. Position cutting station so wind will blow dust away from the user or others in working area.
2. Use one of the following methods based on the required cutting rate:
  - Best**
    - Score and snap
    - Hand guillotine
    - Fibreshear
  - Better**
    - Dust reducing circular saw equipped with HardieBlade™ Saw Blade and HEPA vacuum extraction.
  - Good**
    - Dust reducing circular saw equipped with HardieBlade™ Saw Blade.

### CUTTING INDOORS

- Cut only using score and snap, hand guillotine or fibreshears (manual, electric or pneumatic).
- Position cutting station in a well-ventilated area.

### DRILLING/OTHER MACHINING

When drilling or machining you should always wear a P1 or P2 dust mask and warn others in the immediate area.

### IMPORTANT NOTES

1. For maximum protection (lowest respirable dust production), James Hardie recommends always using "Best" - level cutting methods where feasible.
2. NEVER use a power saw indoors.
3. NEVER use a circular saw blade that does not carry the HardieBlade™ logo.
4. NEVER dry sweep - Use wet suppression or HEPA vacuum.
5. NEVER use grinders.
6. ALWAYS follow tool manufacturers' safety recommendations.

P1 or P2 respirators should be used in conjunction with above cutting practices to further reduce dust exposures. Additional exposure information is available at [www.jameshardie.com.au](http://www.jameshardie.com.au) to help you determine the most appropriate cutting method for your job requirements. If concern still exists about exposure levels or you do not comply with the above practices, you should always consult a qualified industrial hygienist or contact James Hardie for further information.

### Hand guillotine

Make guillotine cut on the off-cut side of line to allow for the thickness of the blade.

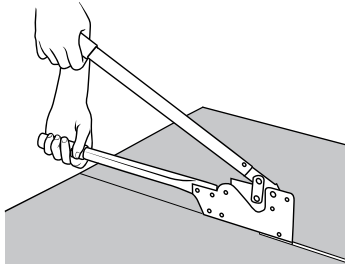

### Fibreshear

An electrically powered, fast, clean and effortless way of cutting James Hardie building products, especially around curves such as archways. Make fibreshear cut on the 'off-cut' side of the line to allow for the thickness of the shear.

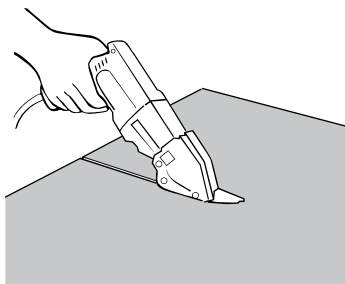

### HardieBlade™ Saw Blade

The HardieBlade™ Saw Blade used with a dust-reducing saw and HEPA vacuum extraction allows for fast, clean cutting of James Hardie fibre cement products. A dust-reducing saw uses a dust deflector or a dust collector which can be connected to a vacuum system. When sawing, clamp a straight-edge to the sheet as a guide and run the saw base plate along the straight edge when making the cut.

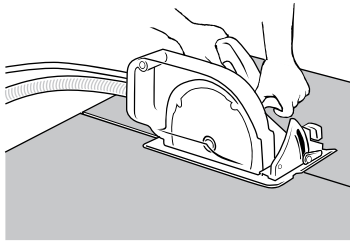

### HOLE-FORMING

#### For smooth clean cut circular holes:

- Mark the centre of the hole on the sheet.
- Pre-drill a pilot hole.
- Using the pilot hole as a guide, cut the hole to the appropriate diameter with a hole saw fitted to a heavy duty electric drill.

#### For irregular holes:

- Small rectangular or circular holes can be cut by drilling a series of small holes around the perimeter of the hole then tapping out the waste piece from the sheet face.
- Tap carefully to avoid damage to sheets, ensuring the sheet edges are properly supported.

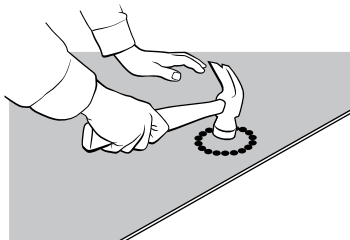

### STORAGE AND HANDLING

To avoid damage, all James Hardie building products should be stored with edges and corners of the sheets protected from chipping.

James Hardie building products must be installed in a dry state and protected from rain during transport and storage. The product must be laid flat under cover on a smooth level surface clear of the ground to avoid exposure to water, moisture, etc.

### QUALITY

James Hardie conducts stringent quality checks to ensure any product manufactured falls within our quality spectrum. It is the responsibility of the builder to ensure the product meets aesthetic requirements before installation. James Hardie will not be responsible for rectifying obvious aesthetic surface variations following installation.

### SUSTAINABILITY

James Hardie® Villaboard™ lining is certified by Australia's only independent, not-for-profit, multi-sector eco labelling program - GECA (Good Environmental Choice Australia), under their Panel Board Standard GECA 04-2011 v2.

GECA's standards are:

- Developed following ISO 14024 principles for global best practice in eco-labeling.
- Formed based on public demand, via a development process that is transparent, consistent, and includes consultation with stakeholders, industry, experts and the general public.
- Rigorous, scientific and relevant to key Australian industries.
- Designed to reward top performing products and services, and are internationally recognised through GECA's membership of the Global Eco-labeling Network.

**GECA certification helps customers have confidence about these products' level of impact on the environment and human health and how they address important social considerations throughout their entire life cycle.**

# 3 FRAMING

## GENERAL

Versilux lining can be fixed to either timber or light gauge domestic type steel framing. The framing used must comply with the relevant building regulations and standards and the requirements of this manual.

## TIMBER

Use only seasoned timber. Unseasoned timber must not be used as it is prone to shrinking and can cause Versilux lining and frames to move.

The minimum stud width is typically 35mm. However where butt jointing is used the minimum stud width is 38mm at the joint. See Figures 13 and 14.

'Timber used for house construction must have the level of durability appropriate for the relevant climate, expected service life and conditions including exposure to insect attacks or moisture, which could cause decay.'

Reference AS1684.2 - 1999 Residential Timber Framed Construction.

## STEEL

The minimum size for steel stud framing should be 64mm deep x 0.55mm base metal thickness (BMT).

Steel framing must be designed in accordance with AS/NZS 4600 - 1996 Cold Formed Steel Structures.

Steel sections shall be galvanised or zinc coated with a minimum BMT of 0.55mm and a maximum BMT of 1.60mm. Studs must not be less than 32mm wide.

## PREPARATION

Ensure frame is square and work from a central datum line. Frames must be straight and true to provide a flush face to receive the sheeting.



**FIGURE 1 FRAME STRAIGHTNESS**

## NOTE

Trim sheets to suit frame if frame is not square.

A suggested maximum tolerance of between 3mm and 4mm in any 3000mm length of frame will give best results. Versilux lining will not straighten excessively warped or distorted frames and any warping may still be visible after the internal lining is applied.

## CURVED WALLS

Versilux lining may be bent to accommodate curved walls. The minimum bending radii are shown, see Table 4.

**TABLE 4**

CURVED WALL MINIMUM BENDING RADII		
	Along length (mm)	Across width (mm)
4.5mm Versilux lining	1200	1800
6mm Versilux lining	1800	2400
9mm Versilux lining	3000	4000

## NOTE

The bending radii given above require no special pre-wetting of the sheet.

To maintain the smoothness of the curve, studs are required at the spacings shown in Table 5.

**TABLE 5**

CURVED LINING - STUD SPACING	
RANGE OF RADII (mm)	STUD SPACING (mm)
1200	150
Above 1200 to 1800	200
Above 1800 to 3000	300
Above 3000 to 20000	450
Above 20000	600

# 4 INSTALLATION

## SHEET LAYOUT

Versilux lining is usually fixed vertically. Sheet joints must coincide with the centre line of the framing member.

### NOTES

- Where horizontal layout is required provide an in-line row of noggings to allow for fastening of the sheet edge.
- All construction must be carried out in accordance with the relevant building regulations and standards.

## FASTENERS

### TIMBER FRAME FASTENER SELECTION

4.5mm, 6mm & 9mm Versilux lining	30mm x 2.8mm Galvanised FC Nail*
----------------------------------	----------------------------------

\*If a smaller head size is desired for aesthetic reasons use 25mm x 2.5mm ring shank underlay nails.

### STEEL FRAME FASTENER SELECTION

	0.55mm-0.75mm BMT	0.8mm-1.6mm BMT
4.5mm Versilux lining	Buildex FibreTEKS® Bugle head 20mm	N/A
6mm Versilux lining	Buildex FibreTEKS® 20mm	Hardiedrive™ screw 32mm
9mm Versilux lining	Buildex FibreTEKS® 30mm	Hardiedrive™ screw 32mm

### NOTES

Fasteners should be driven flush as shown in Figure 2.

Fasteners should be screwed as close as possible to the stud corners to avoid deflection of the stud flange. See Figure 3.

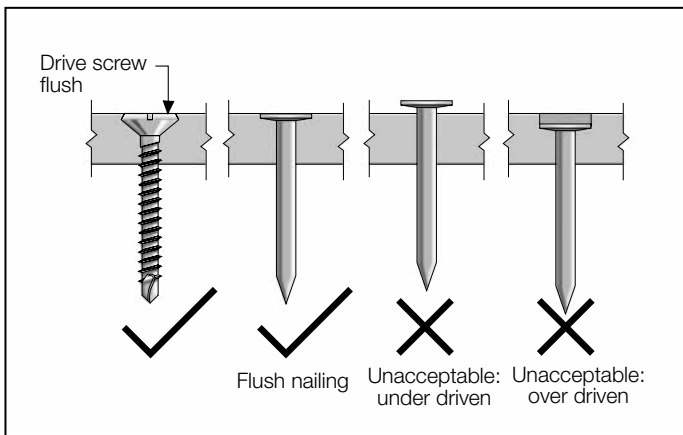

FIGURE 2 FASTENER DEPTH

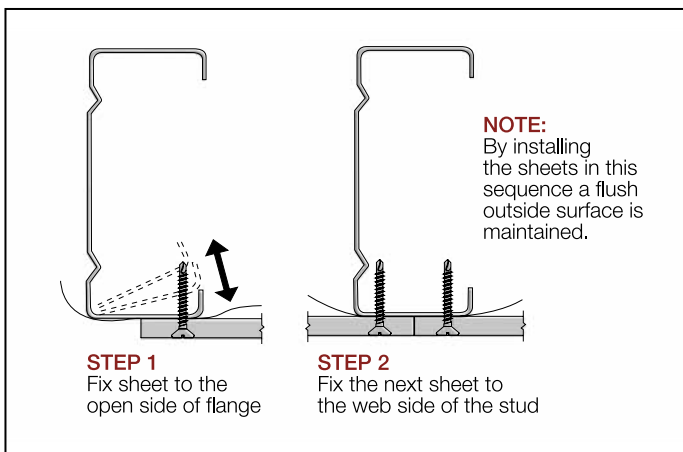

FIGURE 3 SCREW FASTENING

## FIXING TO WALLS

### Step 1

Place 6mm off-cut packers along floor as temporary support for sheets. This allows provision for frame movement. Put sheet in place as shown.



FIGURE 4 SHEET INSTALLATION

### Step 2

Fix sheet starting from the centre of sheet and working outwards to avoid any druminess. For fastener spacings refer to Figure 6.



FIGURE 5 SHEET INSTALLATION

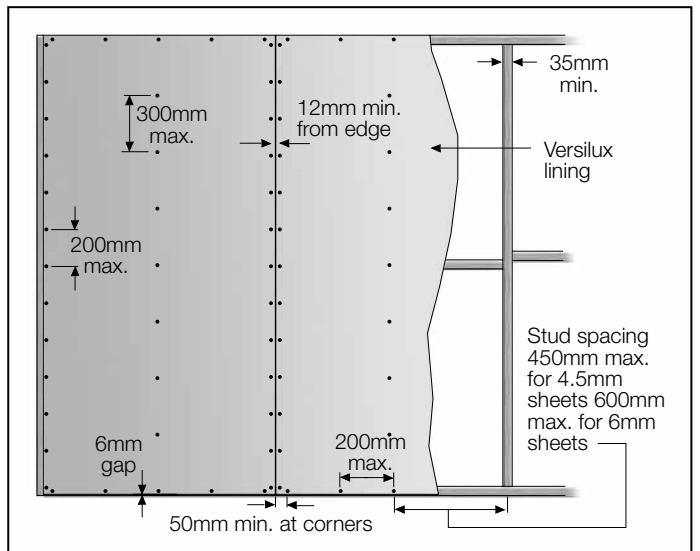

FIGURE 6 WALL FIXING

## FIXING TO CEILINGS

In ceiling applications Versilux lining can be fixed either parallel or perpendicular to framing. See Figures 7 and 8 respectively.

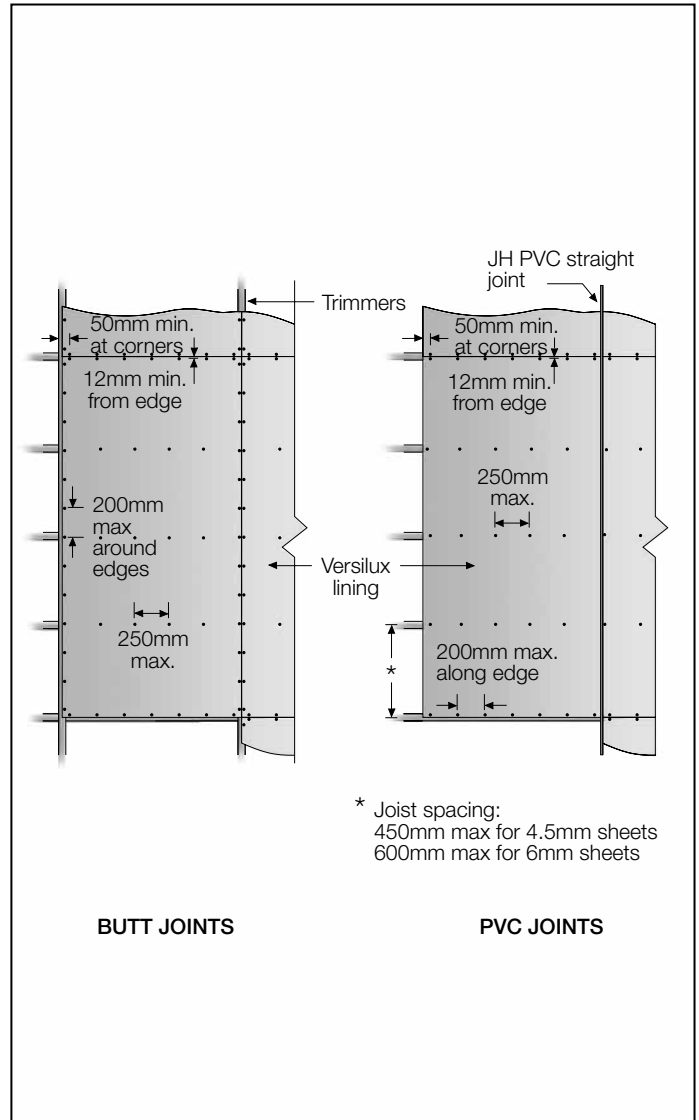
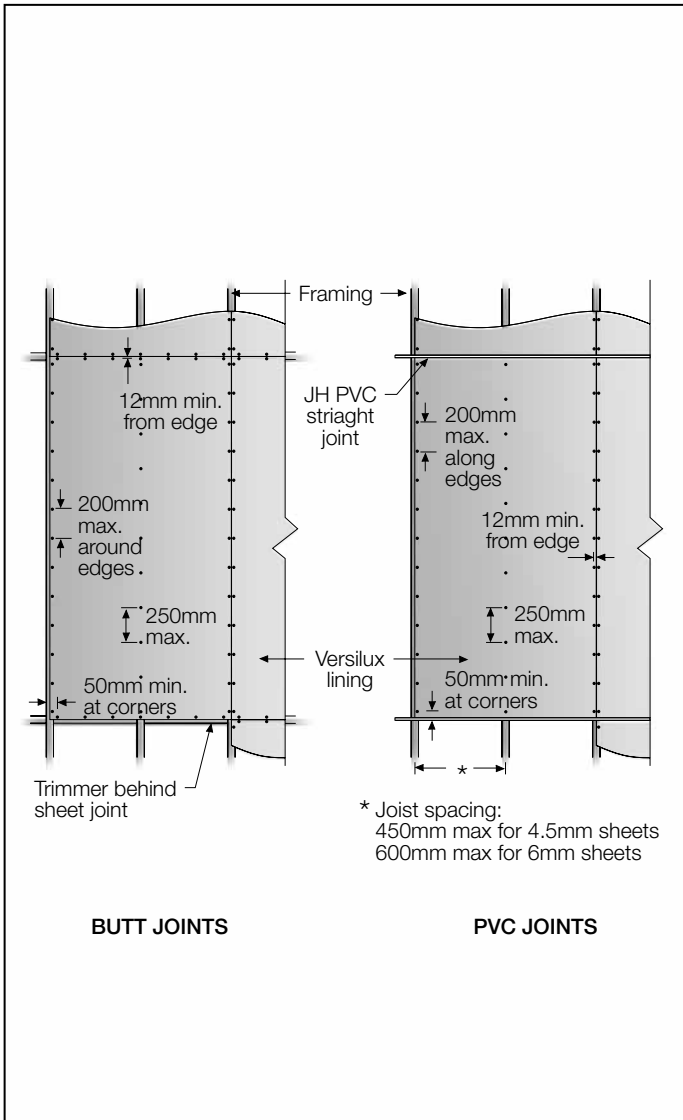

FIGURE 7 CEILING FIXING - PARALLEL TO FRAMING

FIGURE 8 CEILING FIXING - PERPENDICULAR TO FRAME

### NOTE

Do not fix sheets to the bottom chord of roof trusses. Batten these out first with timber battens or metal furring channels.



# 5 JOINTING AND CORNERS

## JOINTING

### PVC jointing

Versilux lining may be jointed using PVC straight jointers as shown in Figures 9-12.

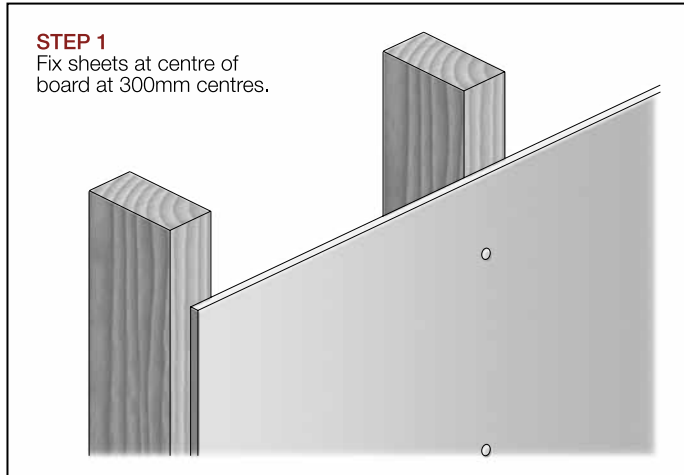

FIGURE 9 STEP 1 - FIX FIRST SHEET

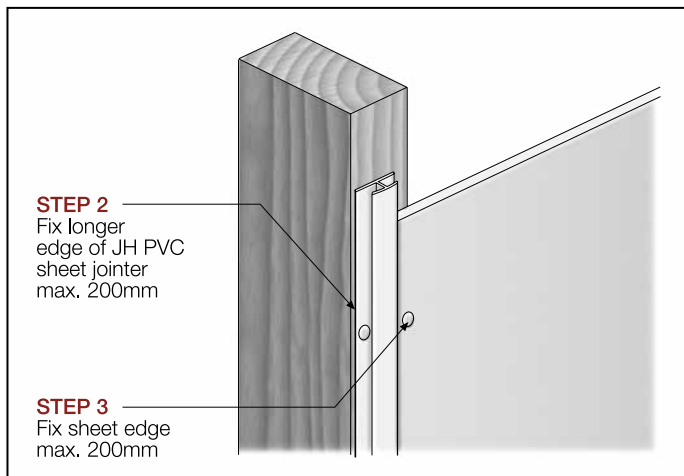

FIGURE 10 STEP 2 - FIX JOINTER

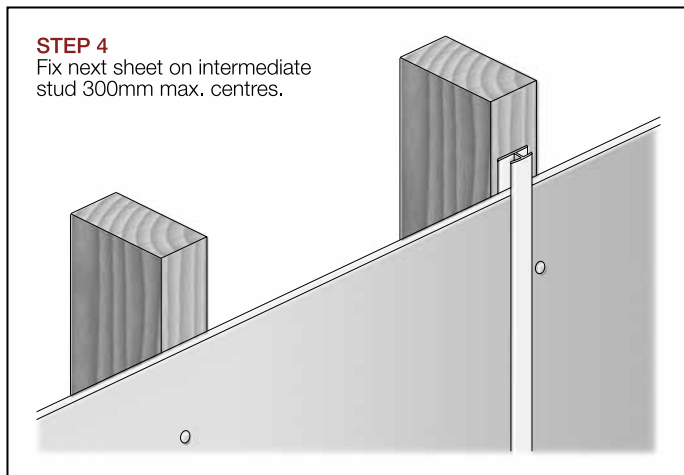

FIGURE 11 STEP 3 - FIX SECOND SHEET

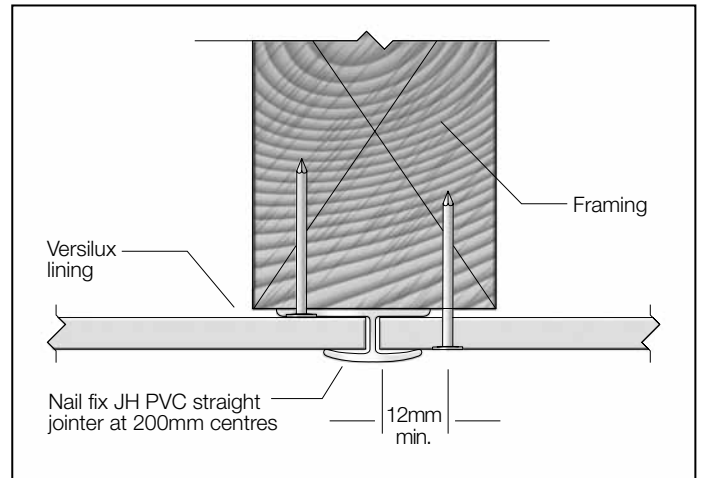

FIGURE 12 PVC STRAIGHT JOINT DETAIL

### Butt jointing

Versilux lining may also be butt jointed by positioning sheet edges along centreline of framing, see Figures 13-14.

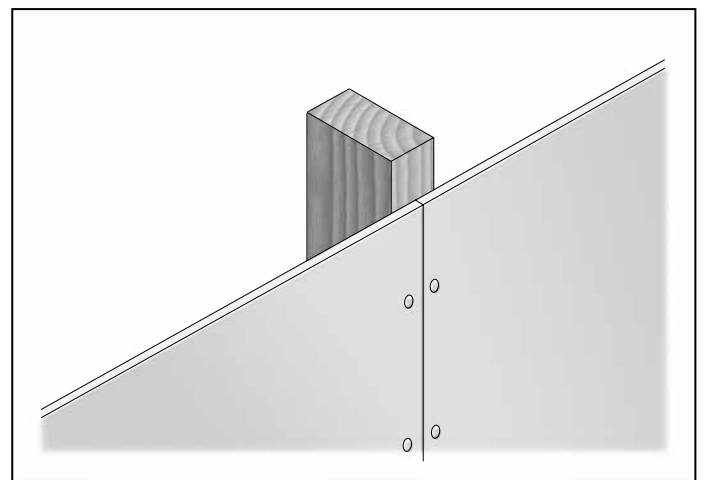

FIGURE 13 SHEET FIXING - BUTT JOINTING

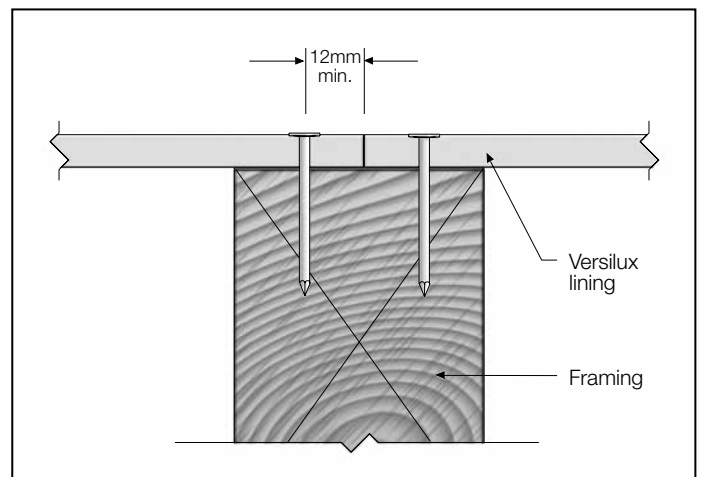
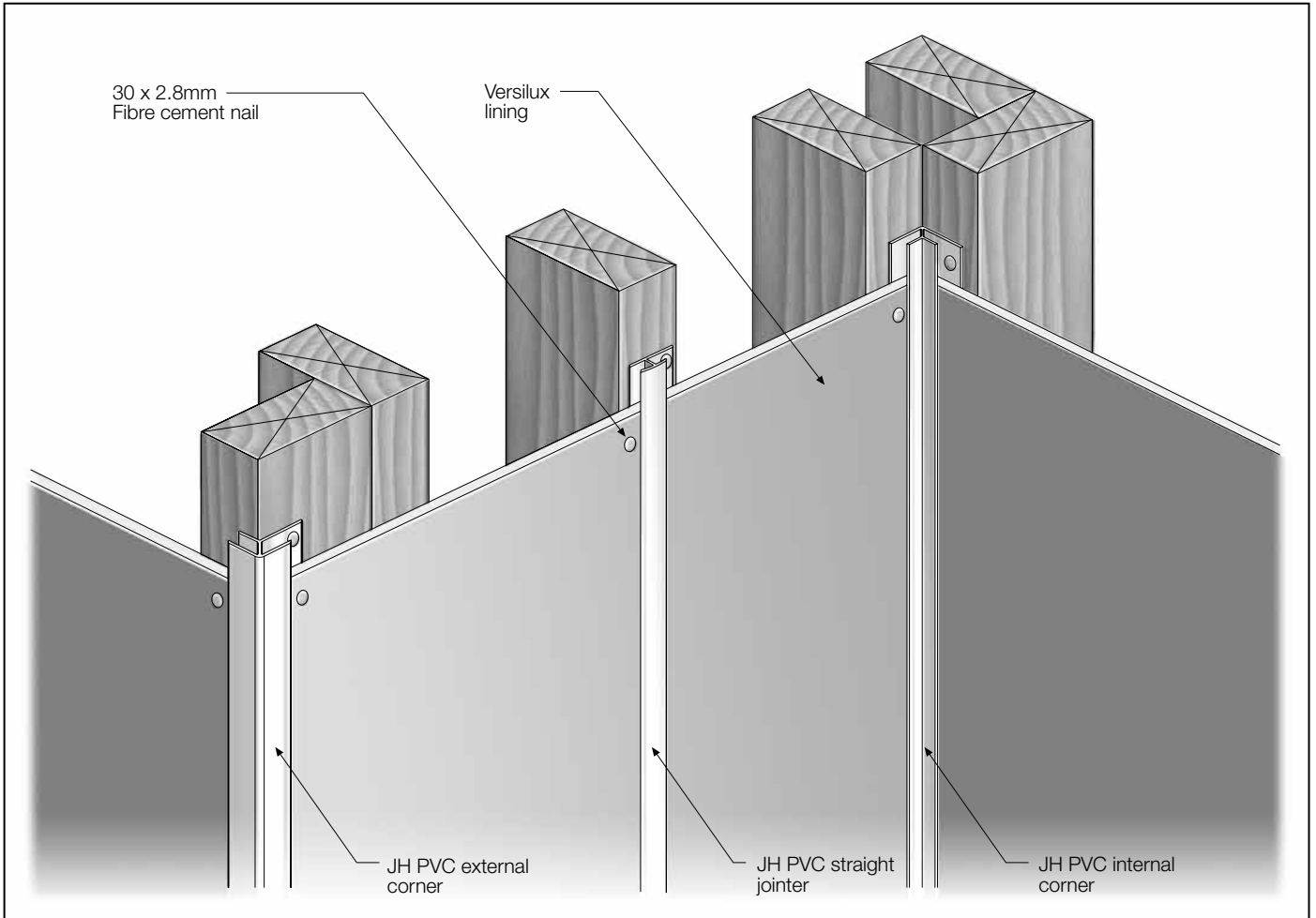

FIGURE 14 BUTT JOINTING DETAIL

## CORNERS

External and internal corners can be finished using the appropriate PVC jointers as shown in Figures 15-17.



**FIGURE 15 CORNER DETAILS**

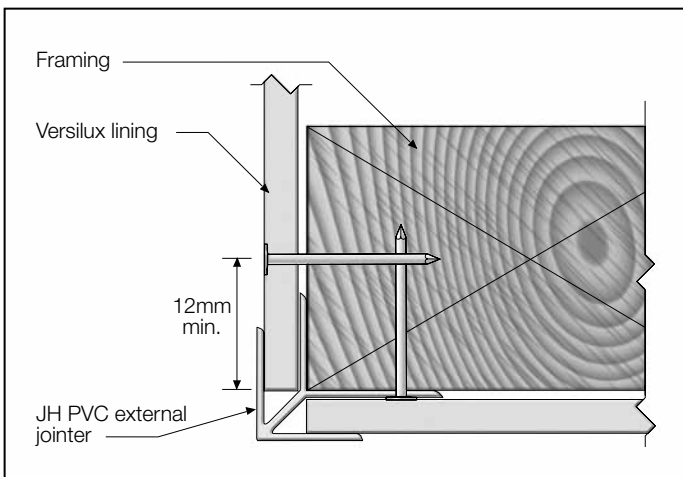

**FIGURE 16 EXTERNAL CORNER**

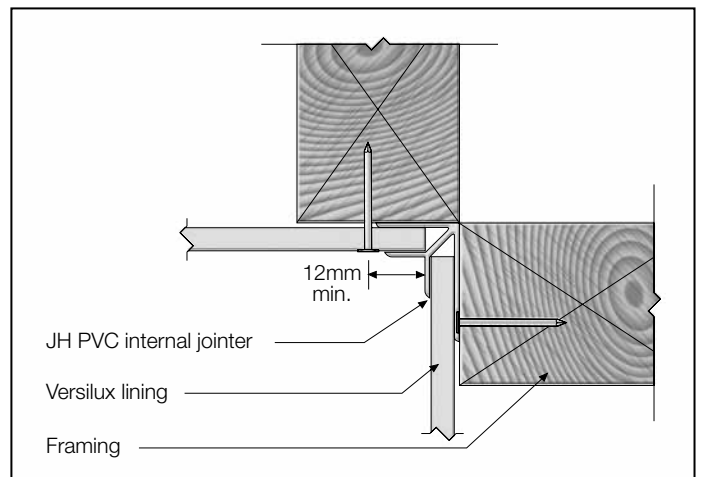

**FIGURE 17 INTERNAL CORNER**

# 6 PRODUCT INFORMATION

## GENERAL

Versilux lining is a cellulose fibre reinforced cement building product. The basic composition is Portland cement, ground sand, cellulose fibre and water.

Versilux lining is manufactured to AS/NZS 2908.2 'Cellulose-Cement Products Part 2: Flat Sheets' (ISO 8336 'Fibre Cement Flat Sheets'). Versilux lining is classified Type B, Category 3 in accordance with AS/NZS 2908.2 'Cellulose-Cement Products'.

For Material Safety Data Sheets (MSDS) visit [www.jameshardie.com.au](http://www.jameshardie.com.au) or Ask James Hardie™ on 13 11 03.

## PRODUCT MASS

The approximate product mass at equilibrium moisture content for 4.5mm, 6mm and 9mm Versilux lining is 6.2, 8.3 and 12.4 Kg./m<sup>2</sup> respectively.

## DURABILITY

### Resistance to moisture/rotting

Versilux lining has demonstrated resistance to permanent moisture induced deterioration (rotting) by passing the following tests in accordance with AS/NZS2908.2:

- Water permeability (Clause 8.2.2)
- Warm water (Clause 8.2.4)
- Heat rain (Clause 6.5)
- Soak dry (Clause 8.2.5)

### Resistance to termite attack

Based on testing completed by CSIRO Division of Forest Products and Ensis Australia James Hardie building products have demonstrated resistance to termite attack.

### Resistance to fire

The Versilux® lining is suitable where non-combustible materials are required in accordance with C1.12 of the Building Code of Australia.

James Hardie building products have been tested by CSIRO in accordance with AS/NZS 3837 and are classified as conforming to Group 1 material (highest and best result possible), with an average specific extinction area far lower than the permissible 250m<sup>2</sup>/kg, as referenced in Specification C1.10a of the BCA.

## FINISHES

James Hardie recommends Versilux lining be coated with a suitable paint finish. Refer to the paint manufacturer for paint suitability, mixing and application.

## MAINTENANCE

James Hardie recommends the cleaning and maintenance of the Versilux lining be undertaken regularly as per the recommendations of the coating manufacturer. Joints must also be maintained and be free of dirt and grime.

# 7 WARRANTY

## Versilux® lining

### 10 YEAR WARRANTY

#### January 2012

James Hardie Australia Pty Limited ("James Hardie") warrants to the first purchaser of Versilux® lining (**Product**) from James Hardie and the last purchaser of the Product prior to installation that, subject to compliance with the Conditions of Warranty below:

- for a period of 10 years from the date of purchase, the Product will be free from defects due to defective factory workmanship or materials; and
- for a period of 10 years from the date of purchase, the Product will be resistant to damage from cracking, moisture, rotting, fire and termites to the extent set out in James Hardie's relevant published literature current at the time of installation; and
- for a period of 12 months from the date of purchase that the accessories supplied by James Hardie will be free from defects due to defective factory workmanship or materials.

For the purposes of this warranty, a "defect" in respect of the Product means a non-compliance with AS/NZS 2908.2:2000 Cellulose-cement products - Flat sheet.

#### CONDITIONS OF WARRANTY

This warranty is strictly subject to the following conditions:

- (a) James Hardie will not be liable for breach of this warranty unless the claimant provides proof of purchase of the Product and makes a written claim to James Hardie at the address set out below, either within 30 days after the defect would have become reasonably apparent or, if the defect was reasonably apparent prior to installation, then the claim must be made prior to installation.
- (b) the Product is subject to natural variation in finish as part of the manufacturing process. The builder/installer must ensure the Product meets aesthetic requirements before installation. Subject to the terms of this warranty, after installation of the Product, James Hardie is not liable for claims arising from aesthetic surface variations if such variations were, or would upon reasonable inspection have been, apparent prior to installation;
- (c) this warranty cannot be relied upon by any other person and is not transferable;
- (d) the Product must be installed and maintained strictly in accordance with the relevant James Hardie literature current at the time of installation and must be installed in conjunction with the components or products specified in the literature. To obtain copies of such literature go to or contact Ask James Hardie™ on 13 11 03. Further, all other products, including coating and jointing systems, applied to or used in conjunction with the Product must be applied or installed and maintained strictly in accordance with the relevant manufacturer's instructions and good trade practice;
- (e) the project must be designed and constructed in strict compliance with all relevant provisions of the current Building Code of Australia, regulations and standards;
- (f) if the claimant chooses to rely upon this warranty then the claimant's sole remedy under this warranty for breach of this warranty is (at James Hardie's option) that James Hardie will either supply replacement Product, rectify the affected Product or pay for the cost of the replacement or rectification of the affected Product;
- (g) In the circumstances where the Australian Consumer Law does not apply in respect of the purchase of the Product, James Hardie will not be liable for any losses or damages (whether direct or indirect) including property damage or personal injury, consequential loss, economic loss or loss of profits, arising in contract or negligence or howsoever arising. Without limiting the foregoing, James Hardie will not be liable for any claims, damages or defects arising from or in any way attributable to poor workmanship, poor

design or detailing, settlement or structural movement and/or movement of materials to which the Product is attached, incorrect design of the structure, acts of God including but not limited to earthquakes, cyclones, floods or other severe weather conditions or unusual climatic conditions, efflorescence or performance of paint/coatings applied to the Product, normal wear and tear, growth of mould, mildew, fungi, bacteria, or any organism on any Product surface or Product (whether on the exposed or unexposed surfaces);

- (h) In the circumstances where the Australian Consumer Law does not apply in respect of the purchase of the Product, all warranties, conditions, liabilities and obligations other than those specified in this warranty are excluded to the fullest extent allowed by law;
- (i) If meeting a claim under this warranty involves re-coating of Product, there may be slight colour differences between the original and replacement Product due to the effects of weathering and variations in materials over time and James Hardie is not liable for any such colour differences;
- (j) In the circumstances where the Australian Consumer Law does not apply in respect of the purchase of the Product and therefore to this warranty, all expenses incurred as a result of claiming under this warranty are to be borne by the claimant.
- (k) In the circumstances where the Australian Consumer Law does apply in respect of the purchase of the Product and therefore to this warranty, if James Hardie accepts or it is determined by James Hardie that the claimant has a valid claim under this warranty, James Hardie will bear the claimant's reasonable costs of claiming under this warranty. The claimant is responsible for all other costs of claiming under this warranty. All claims for such costs are to be notified to James Hardie at the address outlined below within 21 days from when the claimant first makes a claim under this warranty.

#### DISCLAIMER

The recommendations in James Hardie's literature are based on good building practice but are not an exhaustive statement of all relevant information and are subject to conditions (d), (e), (g) and (h) above. Further, as the successful performance of the relevant system depends on numerous factors outside the control of James Hardie (e.g. quality of workmanship and design), James Hardie shall not be liable for the recommendations in that literature and the performance of the relevant system, including its suitability for any purpose or ability to satisfy the relevant provisions of the Building Code of Australia, regulations and standards.

#### IMPORTANT NOTE

If you acquire goods manufactured by James Hardie as a consumer according to the Australian Consumer Law, our goods come with guarantees that cannot be excluded under the Australian Consumer Law. You are entitled to a replacement or refund for a major failure and compensation for any other reasonably foreseeable loss or damage. You are also entitled to have the goods repaired or replaced if the goods fail to be of acceptable quality and the failure does not amount to a major failure.

Any rights a consumer may have under this warranty are in addition to other rights and remedies of a consumer under a law in relation to the goods to which this warranty relates. Nothing in this document shall exclude or modify any legal rights a customer may have under the Australian Consumer Law or otherwise which cannot be excluded or modified at law.

Contact details if you wish to make a claim under this warranty: For more information or to make a claim under this warranty please Ask James Hardie™ on 13 11 03, visit [www.jameshardie.com.au](http://www.jameshardie.com.au) or [www.accel.com.au](http://www.accel.com.au), email James Hardie via our website or write to James Hardie at:

**James Hardie Australia Pty Ltd**  
**10 Colquhoun Street Rosehill NSW 2142**  
**PO Box 70 Parramatta NSW 2124**

© Copyright 2012 James Hardie Australia Pty Ltd. ABN 12 084 635 558. ™ and ® denotes a trademark or registered mark owned by James Hardie Technology Limited

# NOTES

# NOTES

# NOTES

Ask James Hardie™  
Call 13 11 03  
[www.jameshardie.com.au](http://www.jameshardie.com.au)



JHA-2014  
GECA 04-2011 v2  
Panel Boards